

PyroUSB 2.2

PC Configurable Infrared Temperature Sensor for Demanding Applications



- Short-wavelength measurement for low-emissivity targets such as steel rollers and other metal surfaces, even at low temperatures
- Configurable temperature range, emissivity setting etc. from a PC via CalexSoft software and USB cable (supplied)
- Features max, min, average and instantaneous readings; peak or valley hold; reflected energy compensation
- OPC Server capabilities
- Temperature ranges from 45°C to 2000°C
- Emissivity: 0.1 to 1.0
- Stainless steel housing, sealed to IP65
- Field of view: 15:1, 25:1, 75:1 or Close Focus
- Selectable 0 to 20 mA or 4 to 20 mA output
- Optional air/water cooled housing, air purge collar, laser sighting tool and mounting brackets

SENSOR CONNECTION

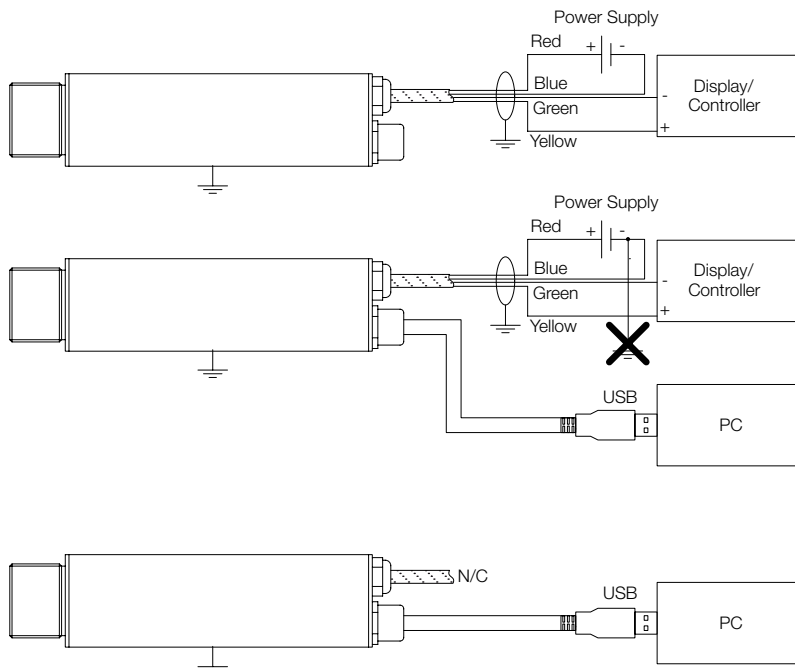

Note: The sensor must be grounded at only one point, either the cable shield or the sensor housing.

The PyroUSB 2.2 Series of infrared pyrometers measures temperatures from 45°C to 2000°C accurately and consistently, with an outstanding response time of 240 ms.

The selectable 0 to 20 mA or 4 to 20 mA output is compatible with almost any indicator, controller, recorder, data logger etc. without the need for special interfacing or signal conditioning.

Model PU151LT2.2 has 15:1 optics and is capable of measuring temperatures from 45°C to 300°C.

For models with temperature range 250°C to 1000°C, or 450°C to 2000°C, a choice of optics is available:

PU251-2.2 models have 25:1 optics and are suitable for most target sizes and distances.

PU751-2.2 models are specially designed for distant targets and have an optical resolution of 75:1.

PUCF-2.2 models are designed for small targets and measure a spot size of \varnothing 7.5 mm at 500 mm distance.

All PyroUSB 2.2 Series sensors are fully configurable from a PC using the CalexSoft software and USB cable supplied. This user-friendly software enables the user to set the temperature range and emissivity setting, compensate for reflected energy; apply filtering; select max, min, average or instantaneous readings; and configure peak or valley hold processing. These features can also be monitored and adjusted by an OPC Client. Other features include data acquisition, alarms and a scrolling graphical display.

The sensor will operate with either the 4 to 20 mA cable connected, the USB cable connected, or both. The USB cable has an IP65 connector at the sensor end. An IP65 cap protects the sensor when the USB cable is not connected.

DIAMETER OF TARGET SPOT MEASURED VERSUS DISTANCE FROM SENSING HEAD

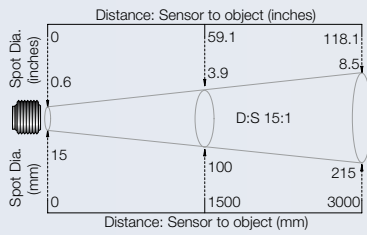

PyroUSB 2.2-151

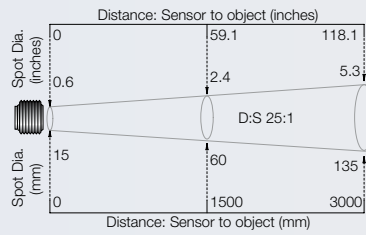

PyroUSB 2.2-251

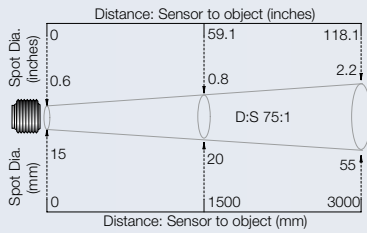

PyroUSB 2.2-751

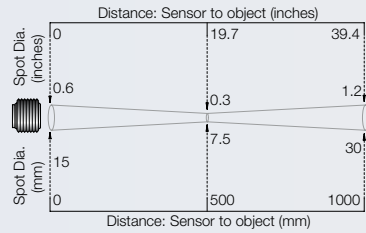

PyroUSB 2.2-CF

GENERAL SPECIFICATIONS

Temperature Range	LT: 45°C* to 300°C (PU151LT2.2 only) MT: 250°C to 1000°C HT: 450°C to 2000°C
Field-of-View	15:1 (PU151LT2.2 only) 25:1 (PU251xT2.2) 75:1 (PU751xT2.2) ø7.5mm @ 500mm (PUCFxT2.2)
Output	Selectable 4 to 20 mA or 0 to 20 mA (linear with temperature)
Configuration	Via PC port conforming to USB 2.0
Accuracy *	±1% of reading or ±2°C, whichever is greater
Repeatability *	±0.5% of reading or ±0.5°C, whichever is greater
Emissivity Setting	0.1 to 1.0
Response Time, t₉₀	240 ms (90% response)
Spectral Range	2.0 to 2.4 μm
Supply Voltage	24 V DC (26 V DC max)
Sensor Voltage	11 V DC min
Max Loop Impedance	900 Ω @ 24 V DC
Maximum Span	Full temperature range (up to 1550°C)
Minimum Span	100°C

* Emissivity = 1.0, object temperature > sensor temperature + 20°C

MECHANICAL

Construction	Stainless Steel
Dimensions	25 mm diameter x 106.5 mm long
Thread mounting	M20 x 1 mm pitch
Weight with Output Cable	175 g
Output Cable Length	1 m
USB Cable Length	1 m

ENVIRONMENTAL

Environmental Rating	IP65
Ambient Temperature	0°C to 70°C
Relative Humidity	95% max. non-condensing

ACCESSORIES



FIXED MOUNTING BRACKET

The L-shaped fixed mounting bracket offers a rigid support for the sensor and allows fine adjustment in a single plane.



ADJUSTABLE MOUNTING BRACKET

The adjustable mounting bracket consists of a fixed mounting bracket plus another L-shaped bracket.

When assembled as shown the adjustable mounting bracket offers a rigid support for the sensor and allows fine adjustment in two planes.



AIR PURGE COLLAR

The air purge collar is used to keep dust, fumes, moisture and other contaminants away from the lens. Air

flows into the fitting on the side and out of the aperture at the front.



AIR/WATER COOLED HOUSING

The air/water cooled housing allows the sensor to withstand ambient temperatures

which exceed the normal 70°C limit. Air or water (depending on the degree of cooling required) flows into one of the fittings on the side and out of the other. To prevent condensation forming on the lens, the air/water cooled housing is supplied complete with an air purge collar. Please note, the air/water cooled housing must be ordered with the sensor and cannot be fitted by the user.



LASER SIGHTING TOOL

The Laser Sighting Tool screws onto the front of the sensor during installation and

indicates precisely where the sensor is aiming. Once the sensor has been aimed at the centre of the target and locked in position the Laser Sighting Tool can be removed. The laser is activated by means of a push button on the front of the tool which has a latching mechanism.

MODEL NUMBERS

PUxxx xx 2.2 xx

Cooling	(blank) = Uncooled sensor
	WJ = Air/water cooled jacket with air purge collar
Temperature range	LT = 45 to 300 °C (model PU151LT2.2 only)
	MT = 250 to 1000 °C
	HT = 450 to 2000 °C
Field of view	151 = 15:1 divergent optics (model PU151LT2.2 only)
	251 = 25:1 divergent optics
	751 = 75:1 divergent optics
	CF = Close-focus optics (focal spot size 7.5 mm at 500 mm distance)

Calex Electronics Limited

PO Box 2, Leighton Buzzard, Bedfordshire, England LU7 4AZ
Tel: +44 (0)1525 373178/853800 Fax: +44 (0)1525 851319 Lo-call Tel: 0845 3108053
E-mail: info@calex.co.uk Online: <http://www.calex.co.uk>

Issue E - Aug 11
Specifications subject to change without notice